

Water fireplace MBM PW 10 left BS

MBM/PW/10/L/BS/W

EAN:

5903950065301

The double glass inserts of the MBM PW line are an economical and ecological solution with a water-based unit, which does not differ from a the typical air insert. Thanks to the unusual vision of the fire and the delicate frame, it perfectly fits into the design of modern interiors.



Technical Specifications

Rated output (kW)	12,0
Average power of the water (kW)	7,0
Range of heating power (kW)	5.0 - 14.0
Efficiency (%)	85,0
The maximum operating pressure (bar)	2,0
Exhaust outlet diameter (mm)	180
Complies with Ecodesign criteria	Yes
Designed for heat recovery unit	Yes
Fuel type	recommended seasoned hardwood with moisture $\leq 20\%$
Weight (kg)	208,5
Water capacity (l)	27,0
CO emission (at 13% O ₂) \leq given in %	0,10
Flue gas temperature (°C)	185,0
Max log length (cm)	50
Emission of dust (mg/Nm ³)	27,0
Compliance with BlmSchV 2 standard	Yes

The energy efficiency index EEI	111,90
Glazing type	lateral
Opening of the doors	to the left
Material	steel
Width (cm)	78,00
Height (cm)	122,00
Depth (cm)	53,00
External air inlet	Yes
The liner of the combustion chamber	Yes
Ashpan	No
Decorative printed glass	Yes
Coil	Yes

Features

The double glass inserts of the MBM PW line are an economical and ecological solution with a water-based unit, which does not differ from a the typical air insert. Thanks to the unusual vision of the fire and the delicate frame, it perfectly fits into the design of modern interiors. This type of fireplace is often chosen for houses with open spaces , such as living rooms with dining areas.

MODERN DESIGN

The insert is equipped with a single, decorative glass, which makes it look elegant and modern. This solution visually enlarges the front of the insert and highlights the vision of the fire.

The door has a comfortable handle.

MAXIMUM ENERGY USE

More efficient burning process and maintaining temperature to keep the warmth for longer, thanks to the lining of combustion chamber with Acumotte -a heat absorbing material that increases the temperature in the combustion chamber.

Afterburning of fuel particles thanks to two deflectors which extend the exhaust path. This process increases the efficiency of burning and guarantees better use of energy. It also minimizes the emission of harmful substances to the atmosphere.

Air supply to the insert comes only from outside, thanks to the built-in air intake connector fi 125 mm. It is controlled by an adjustable throttle with one adjuster below the door. This solution excludes errors of improper use. The whole failure-free mechanism works very quietly.

There is a triple air system of combustion chamber in the insert. Primary air, which facilitates the firing of wood, is provided over the entire width of the burning plate insert, on which the whole process of burning takes place. Non-grate insert offers so-called phenomenon of afterburning of the ashes. Secondary air - providing economical and ecological combustion - is supplied by a system of holes located in the back wall.

In addition, there is a system of clean glass system (air curtain), that means, the air is delivered directly to the glass through channel system located on the sides of the fireplace. In this way air is supplied to the upper part of the combustion chamber, which burns the gases produced by the wood combustion process, which further limits the emission of CO to the atmosphere.

Use of such venting system allows to precisely control the combustion process.

Special unit containing water jacket and horizontally stacked flame tube, through which water flows, allows to gather heat from the flue gases and transfer them to heating system for high energy efficiency. In addition, the device has a built-in coil pipe to protect it from overheating. Water jacket body is reinforced with pins.

Input / output connector to the system - 1 inch, and to the coil pipe ½ inch.

Sturdy and durable to tension fire doors are made of closed profile. The door gasket is in a profiled channel, which guarantees its proper adhesion and prevents it from falling out during operation.

COMFORTABLE USE

The device is equipped with a clean glass system – thanks to so-called air curtain, the airflow is distributed evenly, sweeping the glass and soot settling is reduced to minimum. This allows to maintain an attractive and clean look of glass for a long time.

Insert without grate, with so-called post-combustion of ash. In practice, this means that fuel burns out to ash, which remains in minimum quantity. Heat energy generated in this way is used in maximum.

ECOLOGICAL BURNING

Thanks to its construction and the triple combustion chamber ventilation system, the cartridge meets the Ecodesign requirements.

Technical drawing

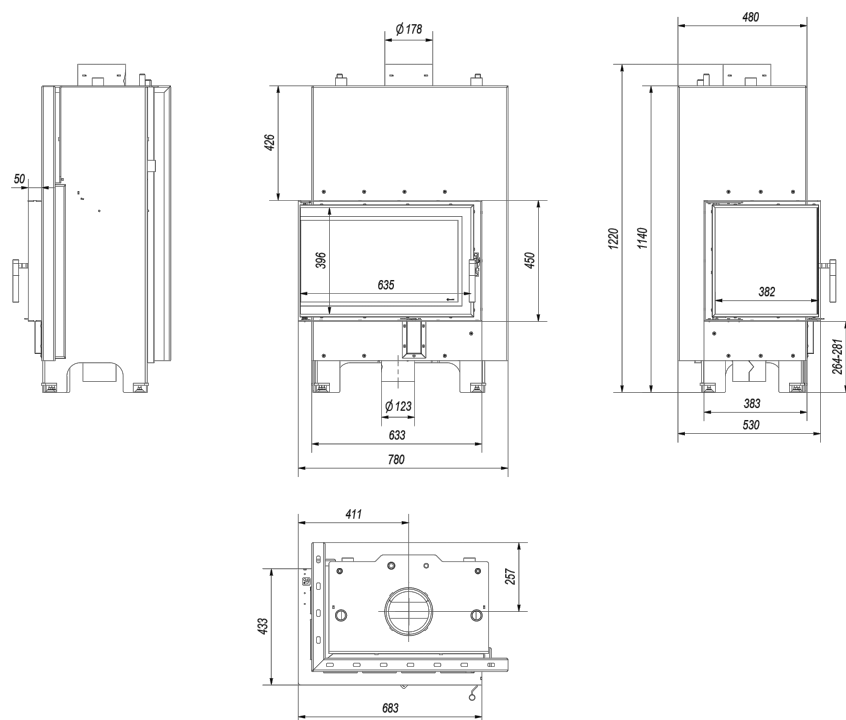

Additional options

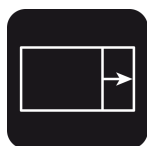

Spring for door shutting AB S/2,
ORBIT MB

120,00 zł

Spring for door shutting - automatically closes the door.



Kratki.pl Marek Bal
ul. W. Gombrowicza 4
26-660 Wsola/Jedlińsk

www.kratki.com
+48 48 338 44 88

Date of publication:
02.09.2018