

Fireplace ZUZIA ECO 12 DECO ZUZIA/ECO/DECO

The ZUZIA ECO series are cast iron inserts with a spacious combustion chamber. The insert has a system of post-combustion of fumes that has not been burnt before, which, along with other technical solutions, has a very good combustion efficiency, which makes the insert meet the strict requirements of the Eco-design.



Technical Specifications

Rated output (kW)	12,0
Range of heating power (kW)	6.0 - 15.5
Efficiency (%)	81,0
Exhaust outlet diameter (mm)	200
Complies with Ecodesign criteria	Yes
Designed for heat recovery unit	No
Fuel type	recommended seasoned hardwood with moisture $\leq 20\%$
Weight (kg)	150,0
CO emission (at 13% O ₂) \leq given in %	0,09
Flue gas temperature (°C)	240,0
Max log length (cm)	50
Emission of dust (mg/Nm ³)	16,0
Compliance with BlmSchV 2 standard	Yes
The energy efficiency index EEI	106,71
The minimum active field of exhaust grilles (cm ²)	≥ 900
The minimum active field of inlet grilles (cm ²)	≥ 700
Glazing type	straight
Opening of the doors	to the left

Material	cast iron, steel
Width (cm)	65,20
Height (cm)	83,30
Depth (cm)	44,80
External air inlet	Yes
The liner of the combustion chamber	No
Ashpan	Yes
Decorative printed glass	Yes

Features

The ZUZIA ECO series are cast iron inserts with a spacious combustion chamber, which are additionally equipped with densely spaced radiators. Thanks to this solution, the surface of heat transfer to the room is much bigger. This increases the mass of the device itself. The insert has a system of post-combustion of fumes that has not been burnt before, which, along with other technical solutions, has a very good combustion efficiency, which makes the insert meet the strict requirements of the Eco-design.

SAFETY AT THE HIGHEST LEVEL

Modern front of the insert is made of steel, equipped with decorative heat-resistant ceramics holding temperature up to 800°C. The glass is certified for quality and safety.

Decorative glass, not only looks elegant and modern, but first of all the use of this solution optically enlarges the front of the insert and highlights the vision of the fire.

The door frame is made of a closed profile, which makes them stable and resistant to stresses when operating at high temperatures.

CONVENIENT USE

The device is additionally equipped with a clean glass system - thanks to the so-called air curtain. The air stream is distributed evenly, sweeps the glass and minimizes the deposition of soot on it. This allows you to maintain a attractive and clean window for a long time.

Keeping the insert clean is easier with a fitted grate and a container where the ash is collected. In addition, the insert has a removable fence, which prevents the wood from falling out of the hearth and makes cleaning of the fireplace easier.

MAXIMUM ENERGY USE

Burning of fuel particles is accomplished due to the equipped deflector which extends the exhaust path. This process also increases the efficiency of combustion and guarantees a better use of energy and at the same time minimizes the emission of harmful substances into the atmosphere.

The device has a triple combustion chamber venting system, therefore the wood burning process in the insert is ecological and most importantly economical.

The supply of primary air to the insert is performed from the outside due to the built-in air inlet (in size of 125 mm). The air intake is located in the bottom part of the insert.

Secondary air is supplied by the holes in the rear wall of the furnace, which creates an afterburning system. The system is responsible for the burning of the gases and the reduction of harmful substances emissions to the environment. It improves the efficiency of the fireplace, what have a direct influence on very low CO emission.

The device is equipped with a clean glass system - thanks to the so-called air curtain airflow is spread evenly, the glass is swept and soot settling is reduced to minimum. This allows you to maintain an effective and clean look of the glass for a long time.

ECOLOGICAL COMBUSTION

Due to the construction of the insert and the triple combustion chamber ventilation system, the cartridge meets the Ecodesign requirements.

Technical drawing

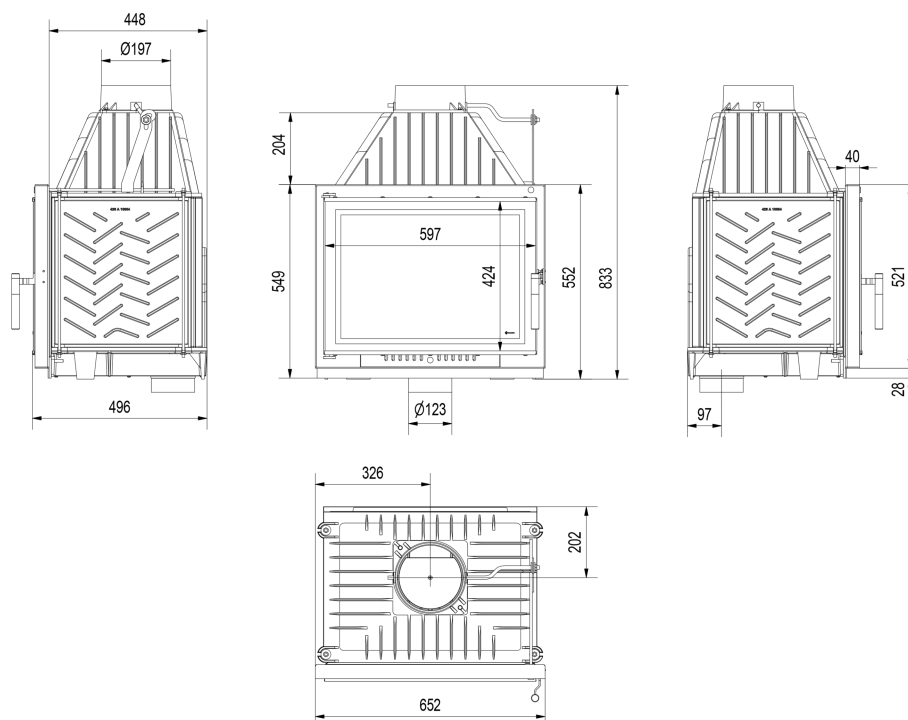

Additional options



Podstawa pod wkład ZUZIA i ERYK

146,00 zł

Podstawa pod wkład ZUZIA, ZUZIA ECO i ERYK umożliwia stabilne ustawienie wkładu kominkowego, możliwość regulacji wysokości nóg.



Steel pipe 200/1m

99,00 zł

Exhaust pipe designed for connecting wood-fired fireplace inserts an the existing flue pipes.



Steel pipe 200/0.5m

68,00 zł

Exhaust pipe designed for connecting wood-fired fireplace inserts an the existing flue pipes.



Movable elbow 200/90

98,00 zł

Adjustable elbow up to 90°, 3-segment, diameter: 200 mm.



The passage from the pipe system

119,00 zł

Ø 200

The passage from the pipe system to the ceramic chimney Ø200.



Kratki.pl Marek Bal

ul. W. Gombrowicza 4
26-660 Wsola/Jedlińsk

www.kratki.com

+48 48 338 44 88

Date of publication:

28.06.2018