

Fireplace LUCY 12 SLIM left BS

LUCY/12/SLIM/L/BS

The insert of an interesting shape with side glazing, with a slim combustion chamber, thanks to which it will be perfect for living rooms with a small area and a small demand for heating power. Thanks to the double-sided vision of the fire and the delicate front frame, it perfectly fits into the style of modern interiors.



Technical Specifications

Rated output (kW)	8,0
Range of heating power (kW)	3.0 - 10.0
Efficiency (%)	83,0
Exhaust outlet diameter (mm)	160
Complies with Ecodesign criteria	Yes
Designed for heat recovery unit	Yes
Fuel type	recommended seasoned hardwood with moisture $\leq 20\%$
Weight (kg)	171,0
CO emission (at 13% O ₂) \leq given in %	0,09
Flue gas temperature (°C)	180,0
Max log length (cm)	35
Emission of dust (mg/Nm ³)	9,0
Compliance with BlmSchV 2 standard	Yes
The energy efficiency index EEI	109,30
The minimum active field of exhaust grilles (cm ²)	≥ 700
The minimum active field of inlet grilles (cm ²)	≥ 500

Glazing type	lateral
Opening of the doors	to the left
Material	steel
Width (cm)	78,10
Height (cm)	128,20
Depth (cm)	41,50
External air inlet	Yes
The liner of the combustion chamber	Yes
Ashpan	Yes
Decorative printed glass	Yes

Features

The insert of an interesting shape with side glazing, with a slim combustion chamber, thanks to which it will be perfect for living rooms with a small area and a small demand for heating power. Thanks to the double-sided vision of the fire and the delicate front frame, it perfectly fits into the style of modern interiors. Modern solutions used in the fireplace guarantee energy savings and make the usage and cleaning of the device trouble-free.

MAXIMUM USE OF ENERGY

More efficient combustion and longer maintenance of temperature by lining the combustion chamber with ceramic material Acumotte which accumulates heat and raises the temperature in the furnace.

Full combustion on the dust thanks to two deflectors which extend the exhaust path. This process increases the efficiency of burning and guarantees better energy use. It also minimizes the emission of harmful substances to the atmosphere.

Air supply to the inserts comes only from outside thanks to the inbuilt air intake connector fi 125 mm. It is controlled by an adjustable throttle with one controller beneath the door. This solution excludes errors of improper use. The whole mechanism works very quietly and flawlessly.

In this insert there is triple air system of combustion chamber. Primary air which enables setting a fire is supplied under the grate. Secondary air - providing economic and ecological burning is supplied by holes on the back wall.

Additionally, this insert is equipped with Clea Galss System (air curtain), so the air is supplied directly to the glass through a system of channels located on the sides of the fireplace. In this way oxygen is supplied to the upper part of the combustion chamber, where happens post-combustion of gases produced while combustion of wood. At the same time it reduces harmful CO emissions to the atmosphere.

Such air system enables to control burning process very precisely.

ECOLOGICAL COMBUSTION

The unit meets the requirements of **Ecodesign** standards and the restrictions of the **BImSchV 2** standard, which determines the maximum CO emission.

SAFETY ON THE HIGHEST LEVEL

Front of the insert is equipped with a heat resistant ceramic withstanding temperatures up to 800°C. We offered by us glass certified quality and safety.

The body and the front of the insert is resistant to high temperatures through the use of high quality steel.

Excellent tightness thanks to the solid welding made in shielded noble gas. Steel elements are laser cut with the help of modern equipment, and then they are bent on CNC benders.

COMFORTABLE USE

Special profiled bottom plate of acumotte is used in this insert. Thank to that the chamber of the fireplace is bigger and larger amount of wood can be put inside. Additionally shallow combustion chamber was used, this results on low demand for heating power. Thanks to this the fireplace perfectly suits to small living spaces.

Movable grate and ash drawer enable to keep the insert clean.

Reduced soot deposition through a system of clean glass system (air curtain). Air curtain separates the glass from the chamber thanks of that the glass doesn't become dirty and emit more heat to the room.

Insert can be easily elevate thanks to the regulated the legs.

The model is equipped with a movable exhaust outlet and thanks to that there is no need to purchase additional knees for installation. It is possible due to easy adjustment of the angle of connection to the chimney system.

MODERN DESIGN

The insert with modern panoramic shape with shallow combustion chamber, thus ideally suited to the living rooms with small area and low demand for heating power. Ideal for energy-efficient and passive homes. Advanced solutions ensure energy saving and make using and cleaning of the fireplace very easy.

The insert has singular decorative glass thanks to that it looks elegant and modern. Such solution visually enlarges the front of the insert and emphasizes the view of the fire.

The door of the insert has comfortable handle.

Technical drawing

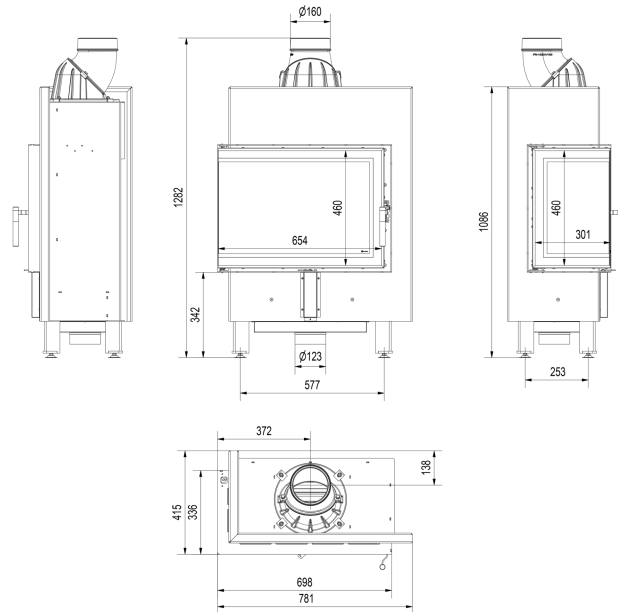

Additional options



Podstawa pod wkład MB, NB i LUCY

123,00 zł

Nogi pod wkłady MB, NB i LUCY umożliwiają stabilne i bezproblemowe ustawienie wkładu kominkowego, możliwość regulacji wysokości.



Steel pipe 160/1m

93,00 zł

Exhaust pipe designed for connecting wood-fired fireplace inserts an the existing flue pipes.



Steel pipe 160/0.5m

61,00 zł

Exhaust pipe designed for connecting wood-fired fireplace inserts an the existing flue pipes.



Movable elbow 160/90

93,00 zł

Adjustable elbow up to 90°, 3-segment, diameter: 160 mm.



The passage from the pipe system

119,00 zł

Ø 160

The passage from the pipe system to the ceramic chimney Ø160.



Kratki.pl Marek Bal

ul. W. Gombrowicza 4
26-660 Wsola/Jedlińsk

www.kratki.com

+48 48 338 44 88

Date of publication:

28.06.2018