

Fireplace LUCY 12 left BS

LUCY/12/L/BS

The insert with interesting shape and side glass. Thanks to double vision of fire and simple front frame it is designed for the modern home, with unique styling. Such types of inserts are good choice for open spaces where different rooms are connected e.g. living room and dining room.



Technical Specifications

Rated output (kW)	12,0
Range of heating power (kW)	5.0 - 15.0
Efficiency (%)	80,0
Exhaust outlet diameter (mm)	200
Complies with Ecodesign criteria	Yes
Designed for heat recovery unit	Yes
Fuel type	recommended seasoned hardwood with moisture $\leq 20\%$
Weight (kg)	194,0
CO emission (at 13% O ₂) \leq given in %	0,10
Flue gas temperature (°C)	270,0
Max log length (cm)	35
Emission of dust (mg/Nm ³)	15,0
Compliance with BlmSchV 2 standard	Yes
The energy efficiency index EEI	105,40
The minimum active field of exhaust grilles (cm ²)	≥ 900
The minimum active field of inlet grilles (cm ²)	≥ 700
Glazing type	lateral
Opening of the doors	to the left

Material	steel
Width (cm)	69,80
Height (cm)	127,00
Depth (cm)	48,00
External air inlet	Yes
The liner of the combustion chamber	Yes
Ashpan	Yes
Decorative printed glass	Yes

Features

The insert with interesting shape and side glass. Thanks to double vision of fire and simple front frame it is designed for the modern home, with unique styling. Such types of inserts are good choice for open spaces where different rooms are connected e.g. living room and dining room. Thanks to specially profiled floor plate the insert can fit bigger volume of wood. Modern solutions used in this insert guarantee energy saving and cause that the service and cleaning are trouble-free.

MAXIMUM USE OF ENERGY

More efficient combustion and longer maintenance of temperature by lining the combustion chamber with ceramic material Acumotte which accumulates heat and raises the temperature in the furnace.

Full combustion on the dust thanks to two deflectors which extend the exhaust path. This process increases the efficiency of burning and guarantees better energy use. It also minimizes the emission of harmful substances to the atmosphere.

Air supply to the inserts comes only from outside thanks to the inbuilt air intake connector fi 125 mm. It is controlled by an adjustable throttle with one controller beneath the door. This solution excludes errors of improper use. The whole mechanism works very quietly and flawlessly.

In this insert there is triple air system of combustion chamber. Primary air which enables setting a fire is supplied under the grate. Secondary air - providing economic and ecological burning is supplied by holes on the back wall.

Additionally, this insert is equipped with Clea Galss System (air curtain), so the air is supplied directly to the glass through a system of channels located on the sides of the fireplace. In this way oxygen is supplied to the upper part of the combustion chamber, where happens post-combustion of gases produced while combustion of wood. At the same time it reduces harmful CO emissions to the atmosphere.

Such air system enables to control burning process very precisely.

ECOLOGICAL COMBUSTION

The unit meets the requirements of **Ecodesign** standards and the restrictions of the **BlmSchV 2** standard, which determines the maximum CO emission.

SAFETY ON THE HIGHEST LEVEL

Front of the insert is equipped with a heat resistant ceramic withstanding temperatures up to 800°C. We offered by us glass certified quality and safety.

The body and the front of the insert is resistant to high temperatures through the use of high quality steel.

Excellent tightness thanks to the solid welding made in shielded noble gas. Steel elements are laser cut with the help of modern equipment, and then they are bent on CNC benders.

COMFORTABLE USE

Special profiled bottom plate of acumotte is used in this insert. Thank to that the chamber of the fireplace is bigger and larger amount of wood can be put inside.

Movable grate and ash drawer enable to keep the insert clean.

Reduced soot deposition through a system of clean glass system (air curtain). Air curtain separates the glass from the chamber thanks of that the glass doesn't become dirty and emit more heat to the room.

Insert can be easily elevate thanks to the regulated the legs.

The model is equipped with a movable exhaust outlet and thanks to that there is no need to purchase additional knees for installation. It is possible due to easy adjustment of the angle of connection to the chimney system.

MODERN DESIGN

The insert has singular decorative glass thanks to that it looks elegant and modern. Such solution visually enlarges the front of the insert and emphasizes the view of the fire.

The door of the insert has comfortable handle.

5 year warranty.

Technical drawing

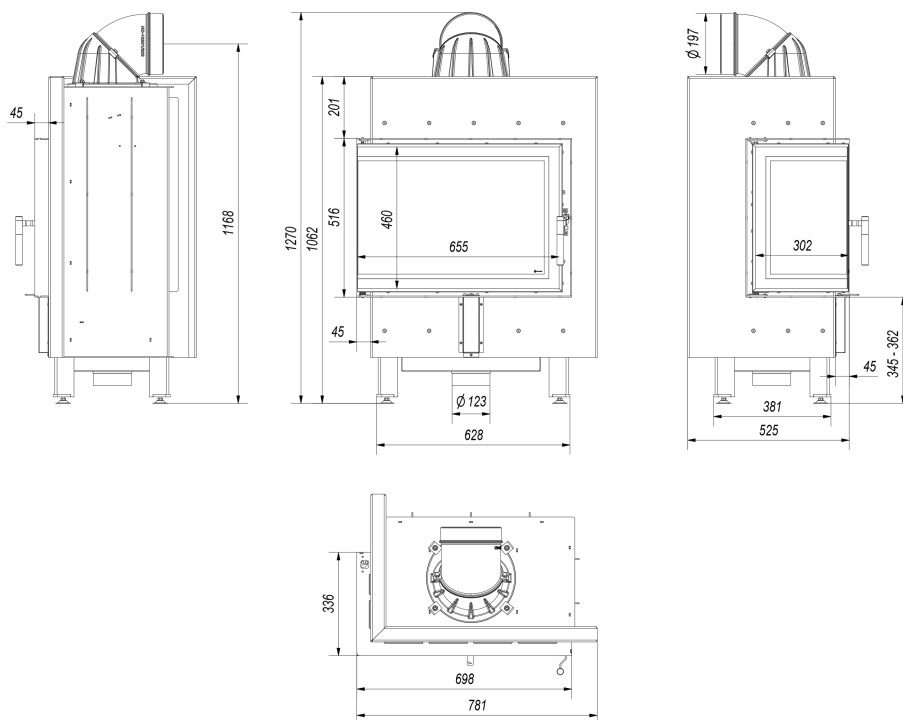

Additional options



Podstawa pod wkład MB, NB i LUCY

123,00 zł

Nogi pod wkłady MB, NB i LUCY umożliwiają stabilne i bezproblemowe ustawienie wkładu kominkowego, możliwość regulacji wysokości.



Steel pipe 200/1m

99,00 zł

Exhaust pipe designed for connecting wood-fired fireplace inserts an the existing flue pipes.



Steel pipe 200/0.5m

68,00 zł

Exhaust pipe designed for connecting wood-fired fireplace inserts an the existing flue pipes.



Movable elbow 200/90

98,00 zł

Adjustable elbow up to 90°, 3-segment, diameter: 200 mm.



The passage from the pipe system $\varnothing 200$

119,00 zł

The passage from the pipe system to the ceramic

chimney Ø200.



Kratki.pl Marek Bal

ul. W. Gombrowicza 4
26-660 Wsola/Jedlińsk

www.kratki.com

+48 48 338 44 88

Date of publication:

28.06.2018